

TeamMate[®] Technical Furniture Solutions

TeamMate makes life simple: with a range of truly innovative furniture solutions to suit any application. Aesthetically pleasing, modular and practical, TeamMate products are designed to stand the test of time.

Conference Tripple

MODEL: CONFTRIPLE

An inspiring statement of multimedia presentation cabinet.

Features & Benefits

- >> Multi configurable with all types of AV/VC and IT equipment.
- >> Three co joined racks give up to 48U of usable rack space.
- >> Built around a natural convection cooling design; no need for additional fans.
- >> Removable side panels for easy integration.
- >> Stylised Black glass top.
- >> No fixed installation: easily redeployed to other areas on 8 lockdown levelling castors.
- >> The Conference Dual unit can support up to 103" diameter screen or twin screens up to 55", to a maximum weight of 250kg.
- >> Full doors in dark Plexiglas finish: keyed alike.
- >> Internal cable management.
- >> Finish silver and stainless steel panels.



Overview

For large boardrooms and high level meeting environments, the TeamMate Conference Triple is at first sight an inspiring piece of office furniture; but within lies a combination of superior rack design. With a natural convection cooling system and a clever mounting system with internal cable management, the Conference Triple can support displays of up to 250kg.

Manoeuvrable on 12 heavy duty castors that lock down once in place, this stylish presentation enclosure combines contemporary design with outstanding functionality, conducive to any business occasion.

Conference Triple: Technical specifications

- >> Three joined racks of 14U x 500mm: total of 42U of rack space.
- >> Additional 6U of usable rack space in side cheeks.
- >> Natural convection cooling design.
- >> One Internal patch panel at rear of rack with 1 IEC power socket supplying 1 x 12way IEC mains distribution unit
- >> Single ventilated rack shelf: one per rack.
- >> 14U full size doors in dark acrylic with suited keys.
- >> Quick release rear panel with suited key.
- >> Removable stainless steel side covers for side access.
- >> 12 lockdown levelling castors.
- >> Worktop in black glass with polished edges supported on 8 stainless steel columns.
- >> Twin columns with cable management via detachable stainless steel panels.
- >> Screen support for up to a maximum screen weight of 250kg.



Conference Triple
TMCONTRIP

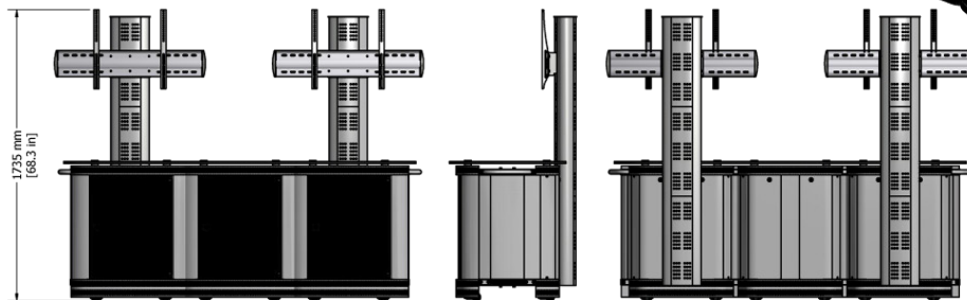
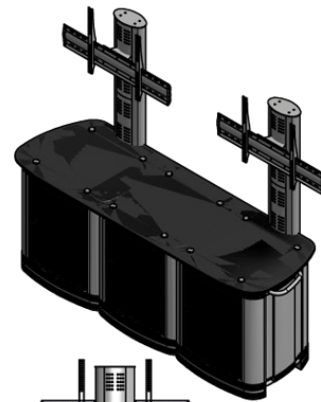
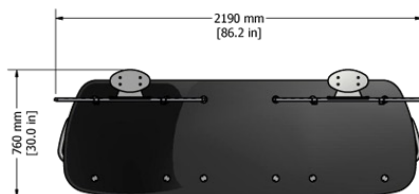

NB: All dimensions are +/- 5mm

Headquarters

TeamMate
EMEA
7 Rockfort Industrial Estate
Hithercroft Road
Wallingford, Oxfordshire
OX10 9DA
United Kingdom

TeamMate
ASIA
D'Piazza Mall
No. 70-3-24, Jalan Mahsuri
Bandar Bayan Baru,
11900 Penang
West Malaysia

TeamMate
AUSTRALIA
25 Quinn Drive
Keilor Park
Victoria
3042 Australia

TeamMate
USA
829 Carswell Avenue
Holly Hill
FL 32117-3513
USA

T: +44 (0) 1491 825739
F: +44 (0) 1491 838568
E: info@teammateworld.com
W: www.teammateworld.com

T: +6 04 643 5739
E: info@teammateworld.com
W: www.teammateworld.com

T: +61 3 9336 1288
F: +61 3 9336 1299
E: info@teammateworld.com
W: www.teammateworld.com

T: +1 (386) 258-9958
F: +1 (386) 258-9798
E: info@teammateworld.com
W: www.teammateworld.com

Date of issue Jan 2014.
These specifications are subject to change.
E&OE.

TeamMate and MediaMate are registered trademarks of Performance Enclosures Ltd.