



# Stage-100<sup>series</sup>

wireless audio systems

## UHF 2-Way Synchronising True Diversity Wireless Microphone System Operation Manual



Thank you for choosing this wireless microphone system!

Our products are designed to last and for user-friendly operation. Each system consists of:

1. A receiver
2. A handheld or beltpack transmitter
3. A pair of antennas
4. A switching adaptor
5. An operation manual

For more details, please take a few moments to read this operating manual to gain a thorough understanding of the function and operation of both transmitter and receiver.

## Parts and functions of IrDA-9000 receiver

### Front panel

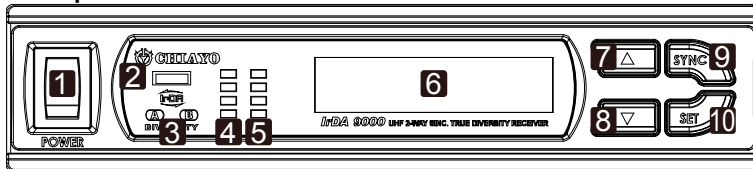

1. Power switch
2. IR sensor area
3. Diversity indicator
4. Radio frequency indicator
5. Audio frequency indicator
6. LCD display
7. UP button
8. DOWN button
9. IrDA synchronisation button
10. SET button

### Rear panel

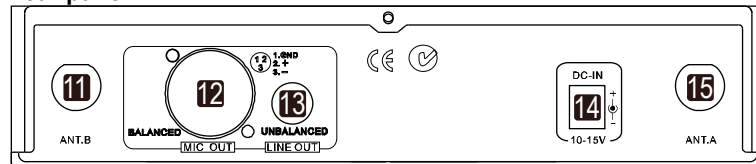

11. Antenna B socket (TNC)
12. Balanced audio output
13. Unbalanced audio output
14. DC in
15. Antenna A socket (TNC)

## Changing CHANNEL / FREQUENCY

CHANNEL:001  
FREQ:800.000 MHZ

First, press "SET" till the display shows

Then press UP or DOWN to select a new channel. As the channel changes, the frequency changes accordingly, too. After the setting is made, the data will be automatically saved.

### CHANNEL scanning

For an interference-free operation, a cleaner channel might be necessary if the current one receives too much interference. Before scanning, the transmitter must be switched off.

AUTO SCAN UP  
AUTO SCAN DOWN

First, press "SET" till the display shows

AUTO SCANNING  
CHANNEL : 002

Then press UP or DOWN to go to the next clean channel.

After the setting is made, the data will be automatically saved.

### CHANNEL SYNCHRONISING of the receiver and microphone

- a. Limit the distance between the receiver and microphone within 30cm.
- b. Align both infrared areas
- c. To change the receiver's channel, please press the synchronising button of the microphone. The receiver's channel will be changed to the same channel as the microphone.
- d. To change the microphone's channel, please press the SYNC button of the receiver and

CH:001 800.000M  
IRDA DATA SEND

will appear on the receiver's display, followed by

CH:001 800.000M  
COPIED BY IRDA

indicating data transferred. Please try again if

CH:001 800.000M  
IRDA SEND FAIL

appears.

### Adjusting VOLUME level

CH:001 800.000M  
VOL: 15 ■■■■■■■■

The setting can be made right on the main menu

Press UP or DOWN to choose a new level. After the setting is made, the data will be automatically saved.

### Adjusting SQUELCH level

SQUELCH SETUP  
LEVEL:01

First, press "SET" till the display shows

Then press UP or DOWN to choose a new level. After the setting is made, the data will be automatically saved.

### Receiver installation

For best operation, the receiver should be at least 1m above the ground and 1m away from a wall or metal surface to minimise reflections. The transmitter should also be at least 1m away from a wall or metal surface to minimise reflections. The transmitter should also be at least 1m away from the receiver. Keep antennas away from noise source such as motors, automobiles, neon light as well as large metal objects.

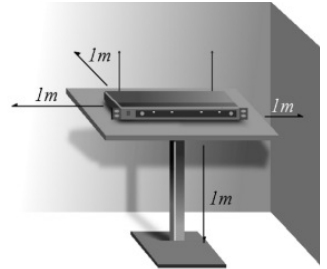

### Audio output connection

There are two audio outputs on the back of the receiver, Mic-level balanced and Line-level unbalanced. Use shielded audio cable for the connection between the receiver and the amplifier/mixer. If the amplifier/mixer has a 1/4"(6.3mm) phone jack, connect a cable from the 1/4"(6.3mm) unbalanced audio output (LINE OUT) from the receiver to the amplifier/mixer. If the amplifier/mixer has an XLR input, connect a cable from the balanced XLR audio output (MIC OUT) from the receiver to the amplifier/mixer input.

### Rack mounting

The receiver can be cabinet-mounted by either one or two units. If only one receiver is to be mounted, an optional kit is available and it's installed as shown in Fig 1. If two receivers are to be mounted, they can be assembled by another kit and installed as shown in Fig 2.

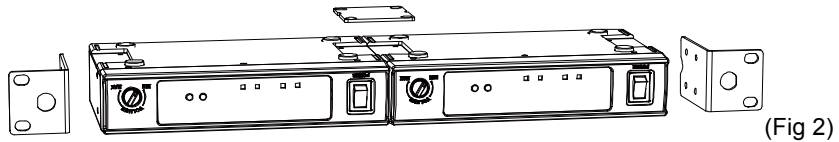
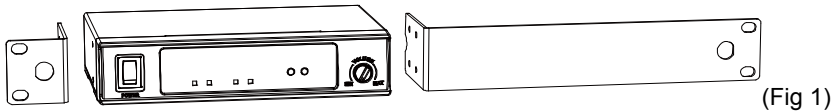

## UHF handheld microphone ( SQ-9000 IrDA )

### Parts and functions

1. Cartridge
2. Battery power LED
3. Power switch
4. LCD
5. Menu button
6. Setting button
7. IrDA synchronising button
8. Battery compartment
9. Color cap
10. IrDA sensor area

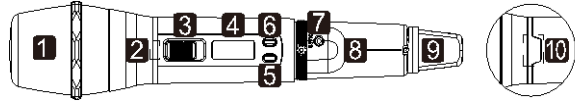

### Battery installation & indicator

This microphone requires 2 x AA batteries to operate.

To install, remove the battery cover and slide the batteries into the battery compartment & replace the battery cover.

**Note:** Batteries contain a corrosive acid that may leak and damage the microphone when stored for a long period. Batteries should be removed from the microphone before storing without use for more than 4 weeks.

When the microphone is switched ON a red LED (2) will blink once to indicate the batteries installed are in good condition. **If the LED remains illuminated the batteries have expired and require replacement.**

### Channel synchronising of the receiver and microphone

1. Limit the distance between the receiver and microphone within 30cm.
2. Align both sensor areas
3. To change the receiver's channel, please press the synchronising button of the microphone

and 

IRDA PLL CALL
------------------

 will appear on the LCD. If the receiver's channel is synchronised, 

PLL SEND OK
----------------

will appear. Otherwise, please try again if the LCD shows 

IRDA FAIL
--------------

.

4. To change the microphone's channel, please press the synchronising button of the receiver. The receiver will transmit synchronising signal to the microphone and change its channel.

## Other settings

### 1. Channel setting

Use **MENU** button to go to the **CHANNEL** page

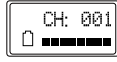

Pressing **SET** button will increase the channel number. The corresponding frequency will change accordingly. 3 seconds after selecting a channel, it will be automatically saved.

### 2. Battery type setting

Use **MENU** button to go to the **BATTERY TYPE** page



Press **SET** button to select either **NIMH** (rechargeable battery) or **AKLN** (alkaline battery). 3 seconds after selecting a channel, it will be automatically saved.

Remark: **NIMH** battery must be selected when rechargeable battery is being used. Never select **AKLN** (alkaline) when microphone is intended for charging, as alkaline battery isn't rechargeable. Wrong battery selection will result in battery sensing electronics to display wrong and misleading status information.

## UHF belt-pack transmitters ( SM-8000 IrDA )

### Parts and functions

1. Antenna
2. Battery power LED
3. Audio mute switch
4. Mini XLR connector
5. IrDA sensor area
6. LCD
7. Charging port
8. Cover release button
9. Power button
10. High-impedance gain control (GT)
11. Low-impedance gain control (MT)
12. IrDA synchronising button
13. Setting button
14. Menu button
15. Battery compartment
16. Charging contacts

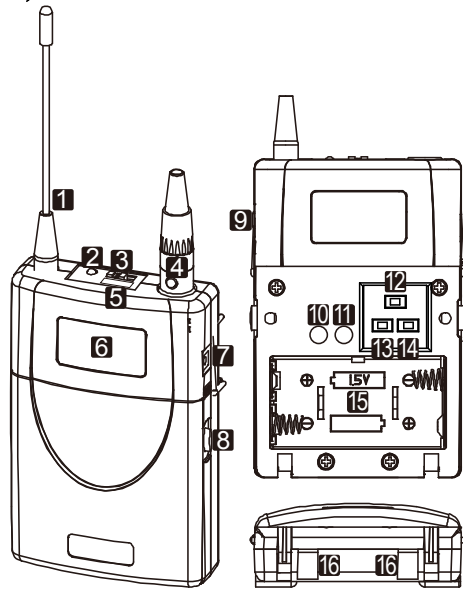

### Battery installation & indicator



This belt-pack requires 2 x AA batteries to operate.

To install, open the battery cover using the cover release buttons and insert the batteries into the battery compartment.

**Note:** Batteries contain a corrosive acid that may leak and damage the belt-pack when stored for a long period. Batteries should be removed from the belt-pack before storing without use for more than 4 weeks.

When the microphone is switched ON, the battery power LED (red) will blink once to indicate the batteries installed are in good condition. **If the LED remains illuminated the batteries have expired and require replacement.**

### Channel synchronising of the receiver and transmitter

1. Limit the distance between the receiver and transmitter within 30cm.
2. Align both sensor areas
3. To change the receiver's channel, please press the synchronising button of the transmitter and  will appear on the LCD. If the receiver's channel is synchronised,  will appear. Otherwise, please try again if the LCD shows .
4. To change the transmitter's channel, please press the synchronising button of the receiver. The receiver will transmit synchronising signal to the transmitter and change its channel.

### GAIN setting (GT/MT)

Gain control enables the user to set different output levels. GT is for the use of instrument with high impedance, such as guitar while MT is for the use of low impedance such as lapel or headset microphones.

### Other settings

1. Channel setting

Use **MENU** button to go to the **CHANNEL** page .

Pressing **SET** button will increase the channel number. The corresponding frequency will change accordingly. 3 seconds after selecting a channel, it will be automatically saved.

2. Battery type setting

Use **MENU** button to go to the **BATTERY TYPE** page .

Press **SET** button to select either **NIMH** (rechargeable battery) or **AKLN** (alkaline battery). 3 seconds after selecting a channel, it will be automatically saved.

Remark: **NIMH** battery must be selected when rechargeable battery is being used. Never select **AKLN** (alkaline) when transmitter is intended for charging, as alkaline battery isn't rechargeable. Wrong battery selection will result in battery sensing electronics to display wrong and misleading status information.



**CHIAYO ELECTRONICS CO.,LTD.**

[Http://www.chiayo.com.tw](http://www.chiayo.com.tw) Email: [sales@chiayo.com.tw](mailto:sales@chiayo.com.tw)

Office: 30, Lane 27, Section 4, Jen-Ai Road, Taipei 10685, Taiwan / Tel: 886-2-27415741 / Fax: 886-2-27525242

Factory: 88, Chung-Hsiao Street 2, Chiayi 60080, Taiwan / Tel: 886-5-2711000 / Fax: 886-5-5767611



