

# Plasma/LCD Stands

## Premium Series

### Mobile Plasma Stand with Cabinet

# AXIS

by GILKON

SPEC SHEET

#### Features

Boardrooms, entrance lobbies, retail displays and many other facilities can be complimented with a plasma display mounted on Gilkon's Axis Mobile Plasma Display Stands with Cabinet. Available in two heights, these units will accommodate virtually any size display up to 80 kg.

Column has cable management. Includes bracket for plasma screen. Bracket can be secured with keyed push button locks to prevent theft. Silver pearl finish. Features lockable accessory cabinet to hold VCR, DVD and related equipment are included.

**Made by Gilkon in Australia.**

#### AXIS MOBILE PLASMA DISPLAY STANDS

Weight Capacity	80 Kg
Suitable for Screens	32" to 50"
Floor to Midpoint of Display - Model 1	1244 mm
Floor to Midpoint of Display - Model 2	1644 mm
Keyed Locks Included	
Codes - Model 1	8FSM AXIS 1C
- Model 2	8FSM AXIS 2C



Screen not included



Manufactured & Distributed By:

  
**WILSON GILKES**  
MANUFACTURING IDEAS

PO Box 63  
Moorebank NSW 1875  
337 - 349 Newbridge Road  
Moorebank NSW 2170

Tel: (02) 9914 0900  
Fax: (02) 9914 0901  
Email: sales@gilkon.com.au

[www.gilkonaxis.com.au](http://www.gilkonaxis.com.au)

# Plasma/LCD Stands

## Premium Series

### Mobile Plasma Stand with Cabinet

# AXIS

by **GILKON**

SPEC SHEET

#### 8FSM AXIS 1C - 1244

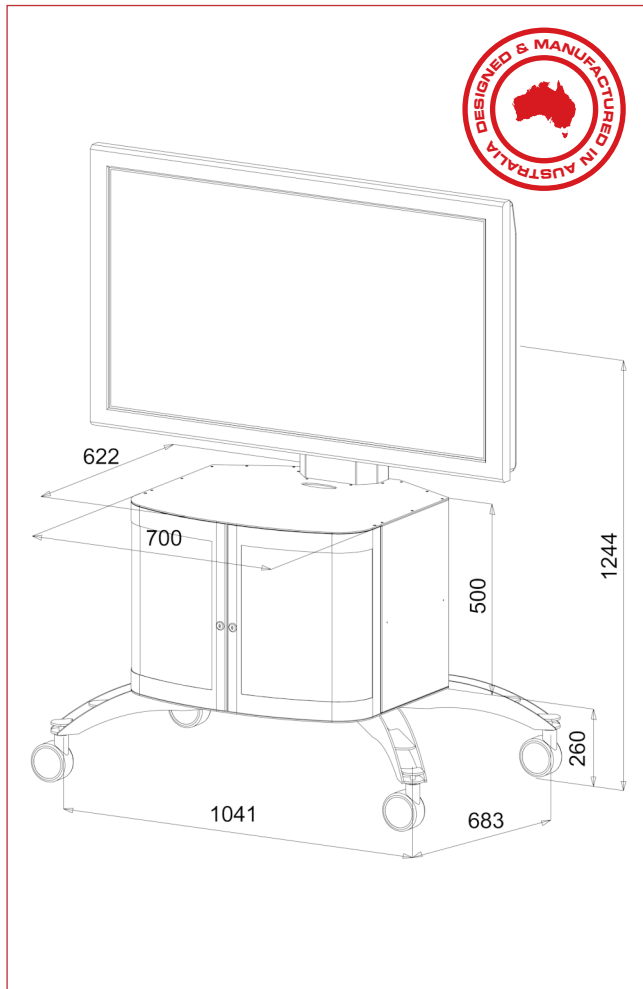

#### 8FSM AXIS 2C - 1644

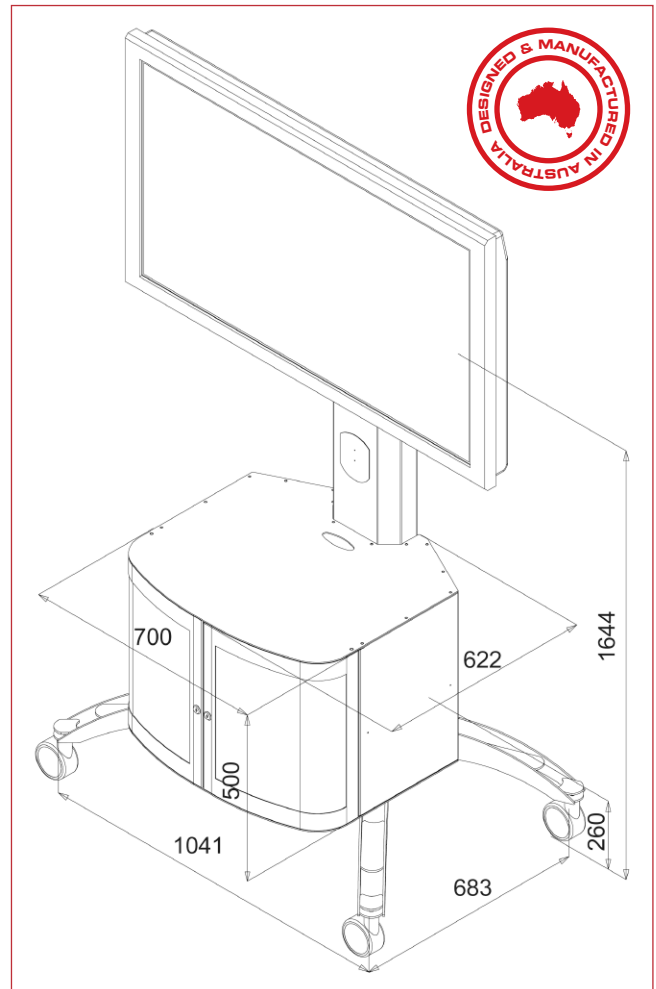

Manufactured & Distributed By:

  
**WILSONGILKES**  
MANUFACTURING IDEAS

PO Box 63  
Moorebank NSW 1875  
337 - 349 Newbridge Road  
Moorebank NSW 2170

Tel: (02) 9914 0900  
Fax: (02) 9914 0901  
Email: [sales@gilkon.com.au](mailto:sales@gilkon.com.au)

[www.gilkonaxis.com.au](http://www.gilkonaxis.com.au)